



AcuityBrands.
Expanding the boundaries of lighting™



Wallpockette® III



Wallpockette® III

Wallpackette® III





Wallpackette® III has been precision engineered utilising proven optical performance to illuminate and limit glare. The precisely moulded prismatic refractor reduces luminaire brightness whilst controlling and directing the maximum amount of light downwards, forwards and sideways to create a uniform horizontal illuminance. With considerable attention given to vandalism, Wallpackette® III is supplied as standard with a tough, durable prismatic polycarbonate front cover, which deters vandals and protects the luminaire from impact damage.

features and benefits

- Robust construction
- > Durability
- Tough prismatic refractor
- > Maximum efficiency & low glare
 - Vandal resistant
- Wide spacing characteristics
- > Cost savings due to reduced number of luminaires
- Emergency lighting versions
- > Improved security

applications

- > Walkways
- > Corridors
- > Tunnels
- > Car parks
- > Loading bays
- > Amenity areas
- > Building perimeters
- > Subways

lamp types included

3000 lumen LED package

IP rating

IP65 

TM66 CEAM-Make rating

Preliminary Rating: 2.1 (Definite/substantial progress to circularity)

approvals

Complies with EN60598

CE

For further information please visit the Holophane website www.holophane.co.uk



specification

The luminaire shall consist of a die-cast aluminium body, housing integral driver and LEDs. The body shall also contain a contoured aluminium reflector used in conjunction with the prismatic one-piece injection moulded polycarbonate or acrylic optical assembly. A sprung latch assembly exerts uniform pressure on the gasket all round ensuring IP65. The luminaire shall be suitable for wall mounting and complies with EN60598, with a choice of options and accessories.

light distributions

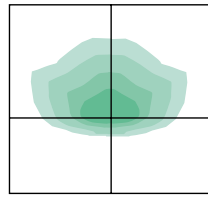

Photometric data is available at www.holophane.co.uk

weights & thermal data

Lamp	TypeWeight (kg)	Min Operating Temperature (°C)	Max Ambient* Temperature (°C)
3000lm LED	5.0	-30	45

* The maximum ambient temperatures stated are for exterior use only. For interior use deduct 10°C from the temperature stated.

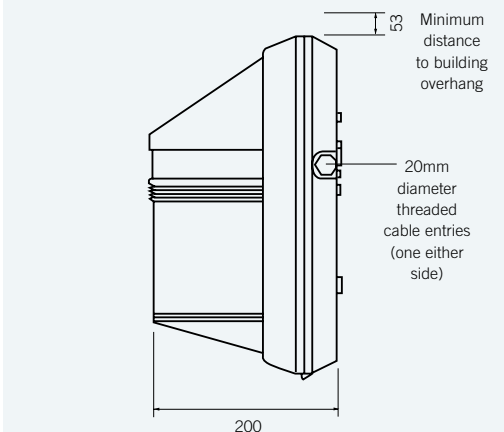
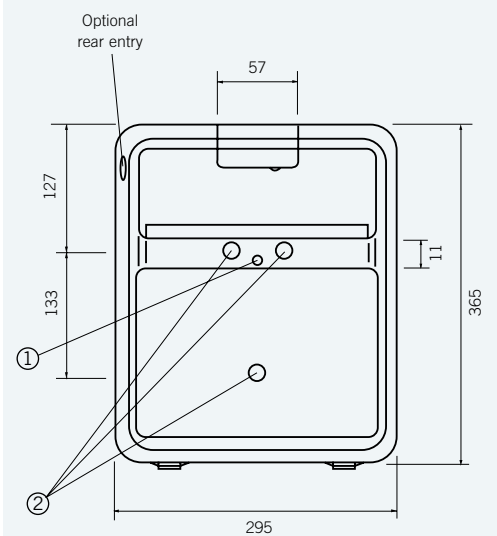

- ① 19mm diameter knockout for supply cable, rear entry
- ② 3 fixing positions screws, plugs and washers supplied

Note: The specifications of the Holophane luminaire and columns represents typical values. All descriptions, illustrations, drawings and specifications in the Holophane catalogue and website represent only general particulars of the goods to which they apply and shall not form part of any contract. The company reserves the right to change specifications at its discretion without prior notification or public announcement.



ordering details : luminaire



Code

WPT	Wallpackette III			
	Code	Lamp Type		
	.LM034	LED light engine producing c. 3,000 lumen with a nominal 4000K colour temperature, 70CRI		
		Code	Colour	
		.C4	Graphite (RAL 7011)	
		.C6	Grey (RAL 7035)	
		.C7	Black (RAL 9005)	
		.RAL****	RAL colour (customer choice)*	
		Code	Options	
		.A	Acrylic lens	
		.C	Enhanced paint finish	
		.P	PG Entry	
		.T	Photocell (Factory Fitted)	
		.TW	Through wiring	
		.EM1	Self contained (self-test) 1hr maintained emergency battery and inverter	
		.EM3	Self contained (self-test) 3hr maintained emergency battery and inverter	
Example	WPT	.LM034	.C4	.P

*Please specify RAL colour reference. Note: Luminaires are supplied as standard for use on 240V 50Hz supply and complete with lamp. For 230V 50Hz add prefix 'N' Other voltages available on request. Timed ignitors as specials available on request.

luminaire accessories

order separately for on-site installation by others

Code

WPT.TC70	Photocell (Retro-fit)
HEL.VK	Vandal Key

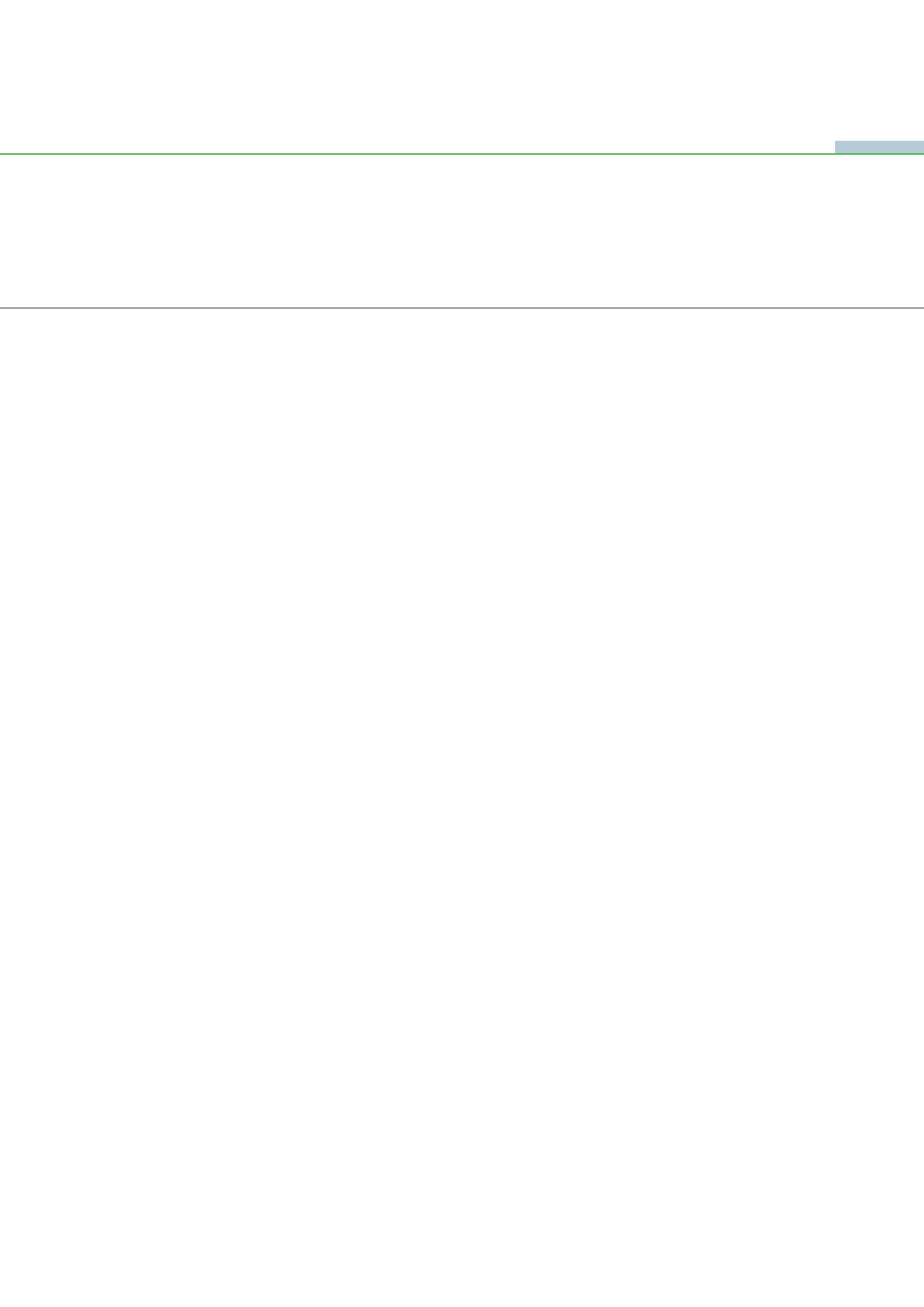



Wallpockette® III

Holophane Europe Limited
Bond Avenue, Bletchley, Milton Keynes MK1 1JG United Kingdom
Telephone: +44 (0) 1908 649292 UK Fax: +44 (0) 1908 367618
International Fax: +44 (0) 1908 363789
E-mail: info@holophane.co.uk

www.holophane.co.uk

