

1

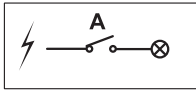

.FM - Flush mount option

.SM - Surface mount option in conjunction with standard BESA box conduit (20mm or 25mm)

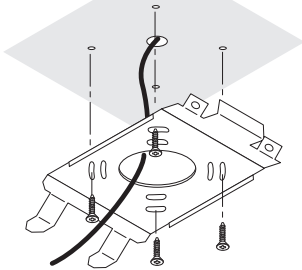

Use appropriate 4mm fastener (x4) supplied by others

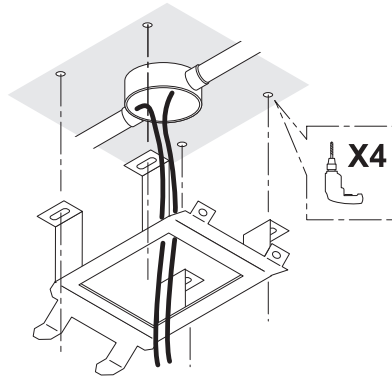

Use appropriate 6mm fastener (x4) supplied by others

2

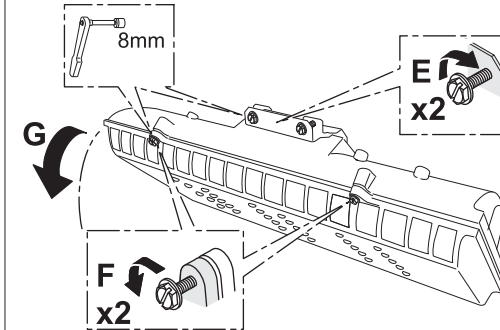
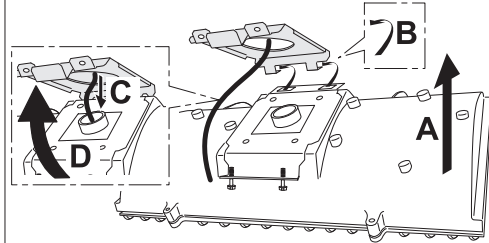

3

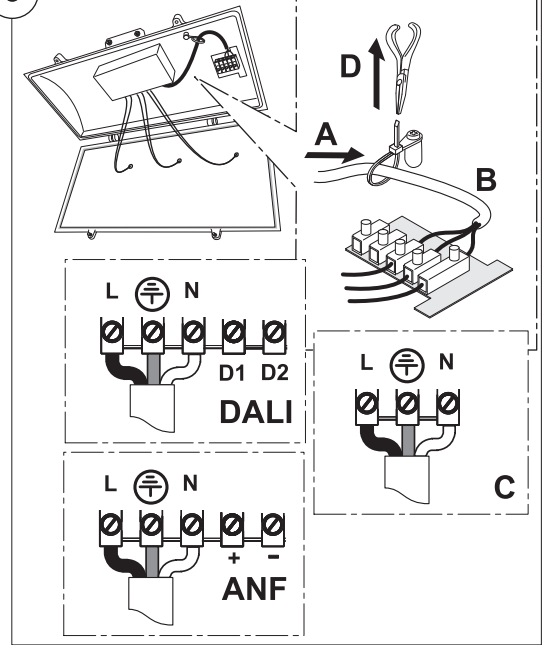

4

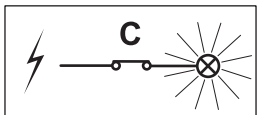
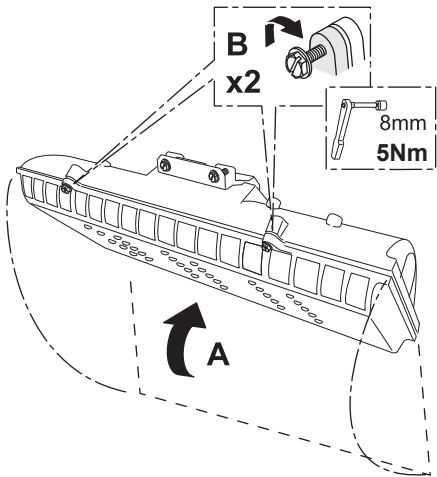

?

.ME Emergency option

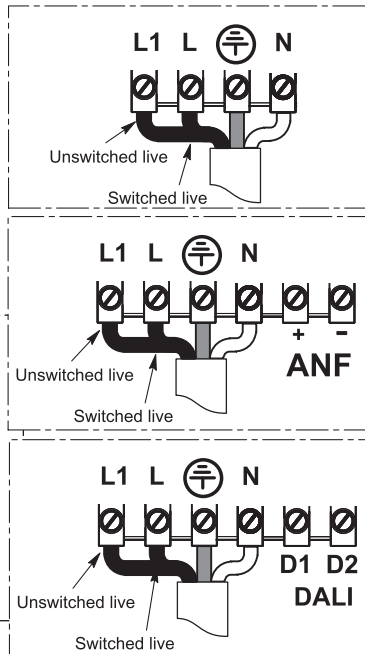
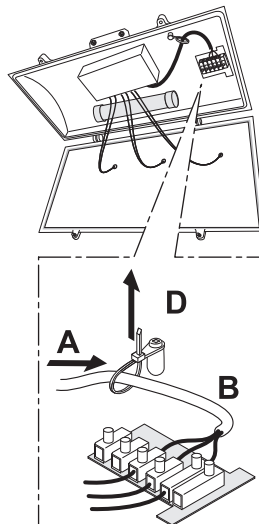

**ISOLATE BOTH MAINS SUPPLY AND DISCONNECT THE BATTERY BEFORE INSTALLATION OR MAINTENANCE.**

**High voltage could be present at the output terminals if the battery is not isolated.**

**Testing/Commissioning**

- Ensure the load is connected.
- Connect the battery.
- Switch on the Unswitched Supply - Check the Charge LED illuminates.
- Switch on the Maintained Supply - Check the LED illuminates at a reduced output.
- Switch off the Maintained Supply.
- Switch off the Unswitched Supply - Check the Charge LED extinguishes and the load LED illuminates at a reduced output.
- Enter the commissioning date on the Battery Pack Switch on the Unswitched Supply.

**Full battery charge time 24 hours.**

